

# Heathfield&Co

## Product Specification Sheet

TABLE LAMP | CAMELLIA



### PRODUCT INFORMATION

Base Code: TL-CAME-SBRS-CRAC  
Material: Ceramic  
Finish shown: Crackle  
Metalwork: Satin Brass  
Lampshade: 12" Medium Drum / SH-12-MEDR  
Flex: UK & EU 1.5 metres of Ivory twisted flex /  
US Ivory braided flex

### TECHNICAL INFORMATION

Weight: 2.3kg / 5lbs  
Plug: White 13amp UK plug /  
White Schuko EU plug / White US polarised plug  
Switching: White inline switch  
Lamping: 1x E27 lampholder / 1x E26 US lampholder  
60W max. LED lamps recommended.  
Lamps not included

BASE HEIGHT: 210 mm / 8<sup>1/4</sup>"  
TOTAL HEIGHT: 490 mm / 19<sup>3/4</sup>"  
BASE WIDTH: 230 mm / 9"  
SHADE WIDTH: 305 mm / 12"

UKCA / CE / UL COMPLIANT

### WARRANTY

10 years\*

### FINISHING NOTE

The ceramic glazes that we have used on this lamp will create differences from piece to piece - variations in colour, formation and detailing. As such, it is part of the charm that no two products are exactly the same.

### CLEANING INSTRUCTIONS

The finishes on this luminaire only require regular cleaning with a soft dry duster. Abrasive or chemical cleaners may harm the finish and should not be used. Shade to be dusted with a clean dry cloth.

\*Please refer to our Terms & Conditions for further information.

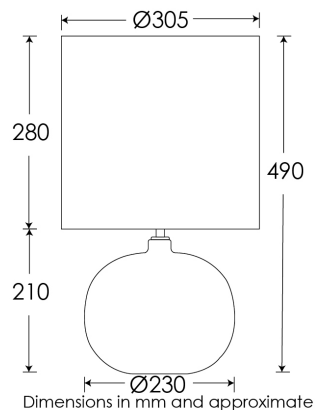

H&CO

LIGHT BEYOND DESIGN