

Last update on 2018-03-11 20:45. More details available at <https://www.aqform.com/en/SX2814>

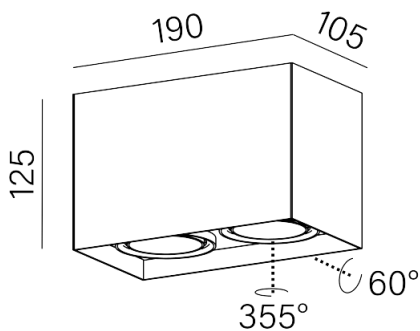

Tolerance for dimensions ± 1 mm

Warranty period 5 years

SQUARES next 50x2 LED surface

SQUARES next 50x2 LED natynkowy

Category: surface

Light source: LED, integrated

Dimming options: Phase-Control, DALI

Integrated light source

Gear included.

4000K on request.

The Quick Shipment offer includes selected product variants marked with the "QS" symbol next to the catalogue number.

This product contains a light source of energy efficiency class E.

AVAILABLE FINISHES:

W&B B&W STRUCTURE



AVAILABLE VERSIONS:

M927	Medium power - Medium power	2700K	CRI>90
M930	Medium power - Medium power	3000K	CRI>90

AVAILABLE FINISHES:

STRUCTURE

black structure	-12	white structure	-13
-----------------	-----	-----------------	-----

B&W

black-white	-62
-------------	-----

W&B

white-black	-63
-------------	-----