

# FLOWER OF LIFE | FLOWER OF LIFE - 500 - SUSPENDED | FOLC-500-S



## DESCRIPTION

A suspended chandelier inspired by the sacred geometry known as the 'flower of life'. Made from lasercut stainless steel frames, chrome plated or lacquered, solid brass components and ballchain in several optional finishes. Illuminated by 7 surface mounted G9 Halogen lamps.

## PRODUCT SIZE

SHADE SIZE: 500W X 630H MM / TOTAL HEIGHT: 1350MM

## PACKAGING DIMENSIONS

610MM(W) X 610MM(L) X 330MM(H)



## LAMP TYPE & NO

7 X G9-HALOGEN 18-40 WATT LAMPS (126-280W) OR LED

## CLASS I

IP RATING 20

QC RATING 21



## VOLTAGE RANGE

110 - 240V

PRODUCT MARKS & RATINGS



WEIGHT 6KG

PACKED 10KG WEIGHT

## TECHNICAL DRAWING

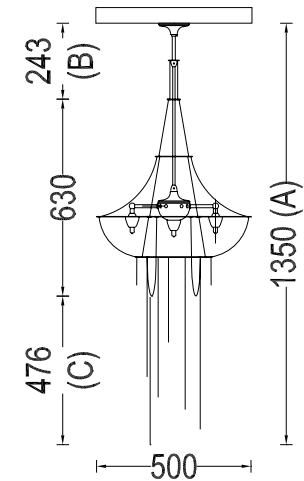
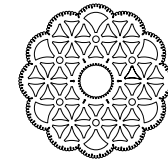

## INTERACT

### SELECT COLOUR

- SILVER \*
- BRASS \*
- COPPER \*
- SMOKE \*
- MIXED METALIC \*
- RUST \*
- WHITE
- RED
- BLACK

### CUSTOMISE DIMENSIONS

A

B

C

### LAMP TYPE

QUANTITY

### ADDITIONAL COMMENTS

PRINT

EMAIL

\* METALLIC