



*Catalogue 2022*  
*Design & Architectural collections*



*X - Rail 48V magnet track system  
sistema a binario magnetico*

X-Rail is a magnet track system with low voltage of 48V, available in the following versions: recessed trimless (only for plasterboard), surface or pendant. The 4 track conductors can be used for an on/off power supply circuit, or for a dimmable "Noise Free" circuit, as described in the wiring schemes.

X-Gun, X-Dark, X-Line and X-Pendant products are suitable for different needs of lighting. They are fixed into the X-Rail profile by the magnet and the click safety lock.

*X-Rail è un sistema a binario magnetico a 48V, disponibile nella versione ad incasso senza bordo (solo per cartongesso), a plafone ed a sospensione. I 4 conduttori del binario possono essere utilizzati per l'accensione on/off, oppure per una dimmerazione "Noise Free", come da schemi di cablaggio. I prodotti X-Gun, X-Dark, X-Line ed X-Sospensioni soddisfano diverse tipologie di illuminazione, e si installano al binario X-Rail attraverso il magnete ed un ulteriore dispositivo meccanico di sicurezza.*

Magnet system  
Sistema magnetico

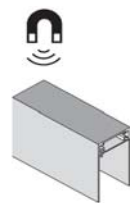

Bidirectional installation  
Installazione bidirezionale

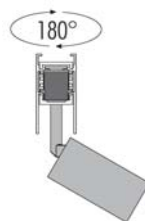

Click & Safety Lock  
Fissaggio meccanico di sicurezza

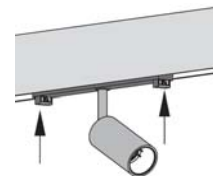

Adjustable  
Orientabile

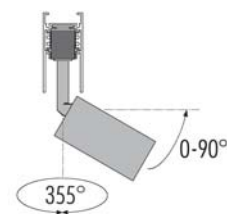

WiFi Technology by App  
Tecnologia WiFi tramite App





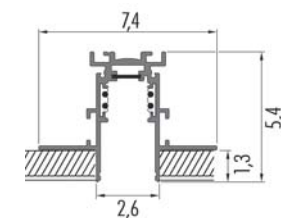

Recessed trimless only for plasterboard - *Incasso senza bordo solo per cartongesso*

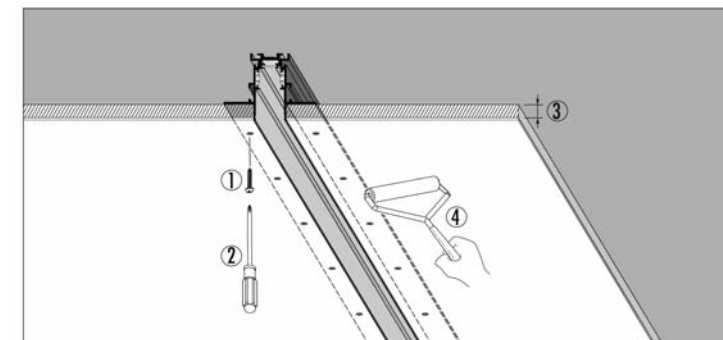

- 1 Screw
  - 2 Screw Driver
  - 3 Gypsum Board 13,3mm
  - 4 Plastering
- 1 Viti
  - 2 Cacciavite
  - 3 Spessore cartongesso 13,3mm
  - 4 Stuccare e rasare

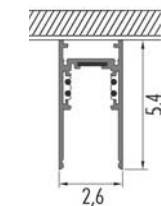

Surface - Plafone

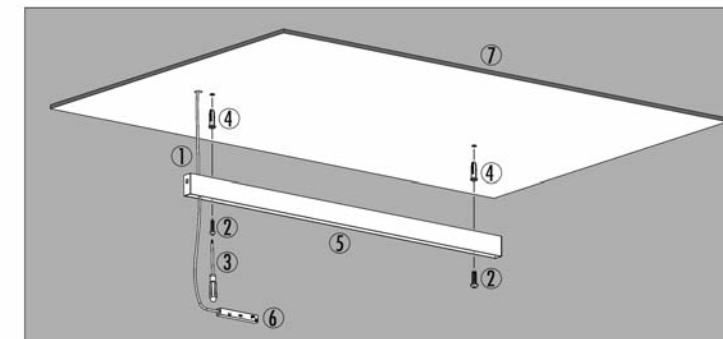

- 1 DC 48V Input
  - 2 Screw
  - 3 Screw Driver
  - 4 Expansion Screw
  - 5 Track
  - 6 DC Connecting Box
  - 7 Ceiling
- 1 DC48V in entrata
  - 2 Vite
  - 3 Cacciavite
  - 4 Tassello
  - 5 Binario
  - 6 Connettore Feed DC
  - 7 Soffitto

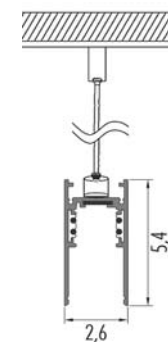

Pendant - Sospensione

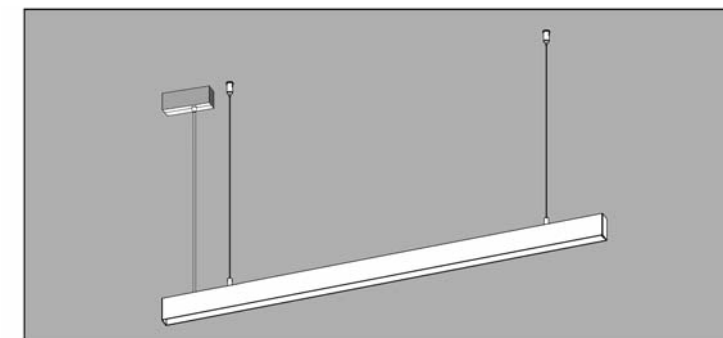

- 1 Steel cable
  - 2 Mounting Plate
  - 3 End cup for track
  - 4 Track
  - 5 Screw
  - 6 Screw
  - 7 DC Connecting Box
- 1 Cavi in acciaio
  - 2 Staffa per sospensione
  - 3 Tappo di chiusura binario
  - 4 Binario
  - 5 Vite
  - 6 Vite
  - 7 Connettore Feed DC

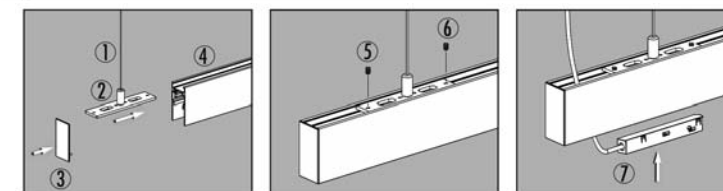

Devices Installation Scheme - Schemi di cablaggio

**Option 1:**  
on/off solution  
soluzione on/off

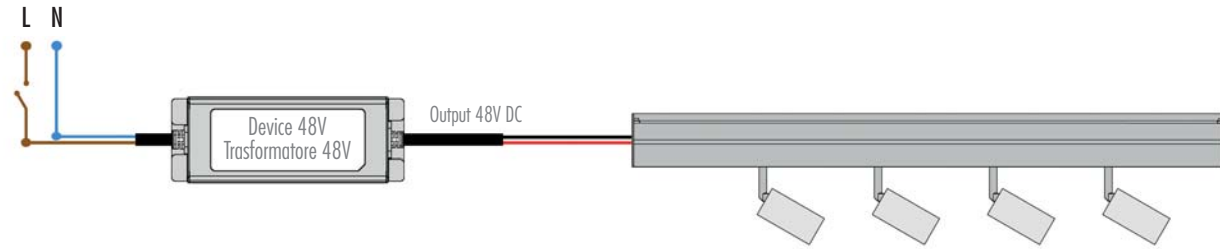

**Option 2:**  
dimnable "Noise Free" DALI: standard addressable solution  
soluzione dimmerabile "Noise Free" tramite riconoscimento standard

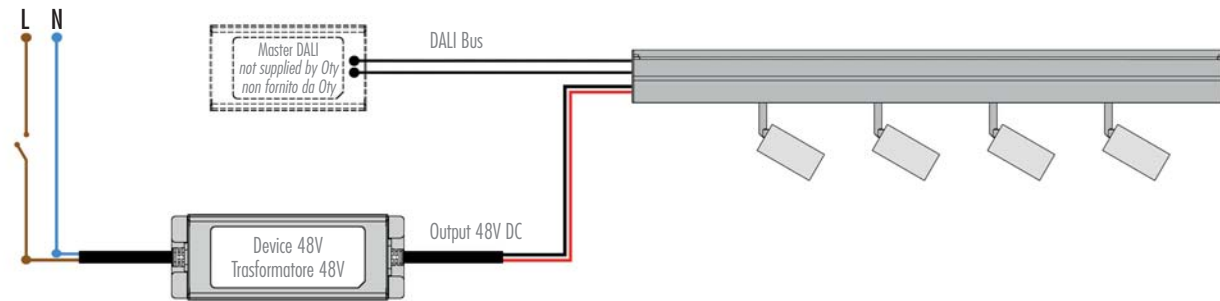

**Option 3:**  
dimmable "Noise Free" WiFi: auto addressable solution  
soluzione dimmerabile WiFi "Noise Free" tramite riconoscimento auto indirizzante

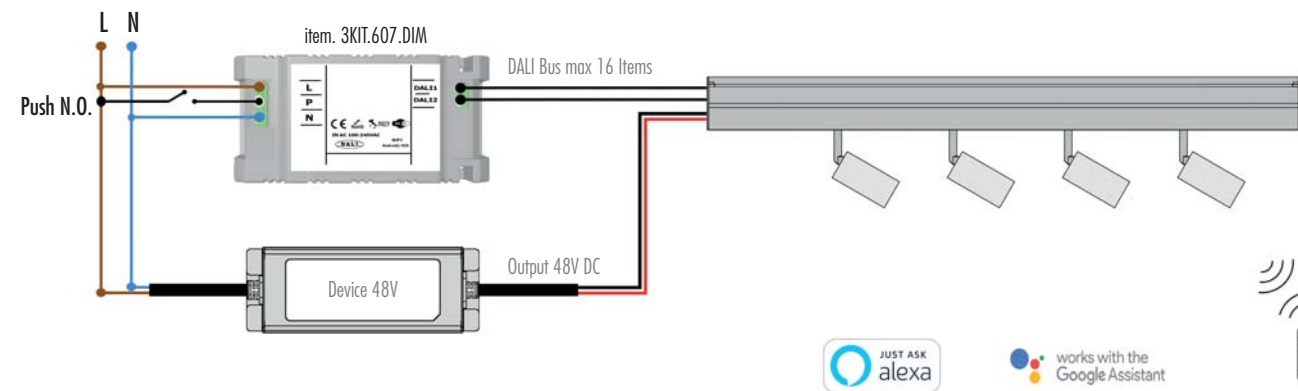

Drop voltage table - Tabella caduta di tensione

Device	(A)	5 mt.	10 mt.	20 mt.	30 mt.
100W	(B)	50 mt.	50 mt.	30 mt.	10 mt.
150W	(B)	20 mt.	15 mt.	5 mt.	—
240W	(B)	15 mt.	10 mt.	—	—

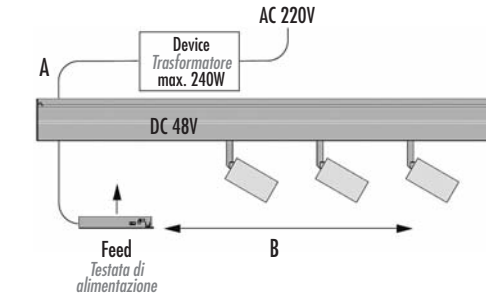

(A) Distance Device/Feed Unit  
(A) Distanza dal trasformatore alla testata di alimentazione.  
(B) Distance Feed Unit/Spot  
(B) Distanza dalla testata di alimentazione all'ultimo articolo.

Technical characteristics of the devices for 48V Track - Caratteristiche tecniche dei dispositivi per binario 48V

Code	W	Size (mm)	CV	Connectable fixtures	Max distance	Cable section	Tech. Info
3KIT.048.100	100	199x63x36	48V	Max: 70W	See chart here above	2.5mm <sup>2</sup>	100-305V 47-63Hz
3KIT.048.150	150	219x63x36	48V	Max: 105W	See chart here above	2.5mm <sup>2</sup>	100-305V 47-63Hz
3KIT.048.245	240	244x71x38	48V	Max: 150W	See chart here above	2.5mm <sup>2</sup>	100-305V 47-63Hz

Led warranty ONLY when used together with devices bought from Oty srl  
I Led sono coperti da garanzia solo se utilizzati in abbinamento con i dispositivi acquistabili dalla Oty srl.

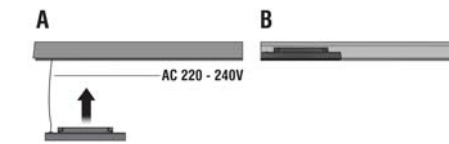

Technical characteristics of the device for 48V Track  
Caratteristiche tecniche del dispositivo per binario 48V

Code	W	Size (mm)	CV	Connectable fixtures
3KIT.048.060	60	242mm	48V	Max: 48W
Tech. Info	120-277V		47-63Hz	

WiFi device "Noise Free" to dim the light -  
Dispositivo dimmerabile WiFi "Noise Free"

Code	Size (mm)
3KIT.607.DIM	80x40x25mm

It works by WiFi with smart phone, Google Assistant or Amazon Alexa. App on request.  
Il dispositivo lavora in WiFi tramite smartphone, con Assistente Google o Alexa Amazon. App su richiesta.



Recessed trimless - *Incasso senza bordo*



<b>1XR5.100.02</b>	100cm	Black - Nero
<b>1XR5.100.06</b>	100cm	White - Bianco
<b>1XR5.200.02</b>	200cm	Black - Nero
<b>1XR5.200.06</b>	200cm	White - Bianco
<b>1XR5.300.02</b>	300cm	Black - Nero
<b>1XR5.300.06</b>	300cm	White - Bianco



**1XR5.GAI.02** Black - Nero

Non electrified vertical internal corner - *Angolare interno verticale non elettrificato*

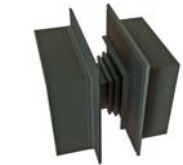

**1XR5.GAE.02** Black - Nero

Non electrified vertical external corner - *Angolare esterno verticale non elettrificato*



**1XR5.GAH.02** Black - Nero  
**1XR5.GAH.06** White - Bianco

Non electrified horizontal corner. *Angolare orizzontale non elettrificato*



**1XR5.GF1.02** Bracket - Staffa

3 Units to connect each linear track, or 6 units to connect two linear tracks to a singular angular (horizontal or vertical) connector.

*Ordinare 3 staffe per unire due binari lineari. Ordinare 6 staffe per unire due binari lineari ad un profilo angolare (orizzontale o verticale).*

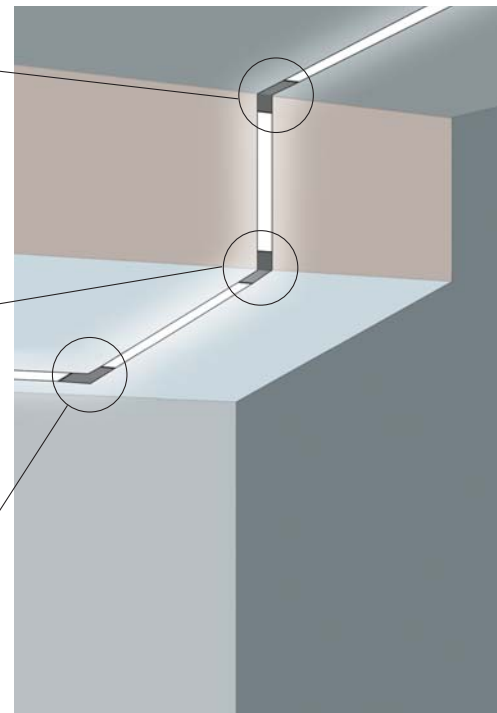
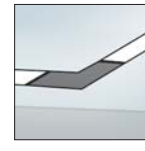
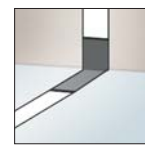

**1XR5.PT1.02** 100cm

Plaster installation guard. Black color

*Copertura in PVC per protezione del binario durante l'installazione su cartongesso. Colore nero*

Surface | Pendant - *Plafone / Sospensione*



<b>1XR2.100.02</b>	100cm	Black - Nero
<b>1XR2.100.06</b>	100cm	White - Bianco
<b>1XR2.200.02</b>	200cm	Black - Nero
<b>1XR2.200.06</b>	200cm	White - Bianco
<b>1XR2.300.02</b>	300cm	Black - Nero
<b>1XR2.300.06</b>	300cm	White - Bianco



**1XR2.GL1.01** 150cm  
**1XR2.GL2.01** 300cm  
**1XR2.GL3.01** 500cm

Long bracket for pendant track with steel cable  $\varnothing$  1,5 mm  
*Staffa per binario a sospensione con cavo in acciaio  $\varnothing$  1,5mm*

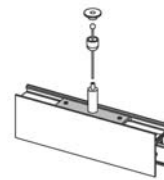

**1XR2.GAH.02** Black - Nero  
**1XR2.GAH.06** White - Bianco

Non electrified corner for surface and pendant track  
*Angolare non elettrificato per binario a plafone e/o sospensione*

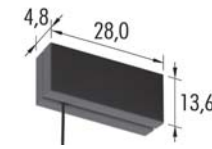

*Canopy - Rosone: On/Off 48V - 75W*

**3XR2.C01.02** Black - Nero  
**3XR2.C01.06** White - Bianco

Wire - Cavo elettrificato: 150cm

**3XR2.C02.02** Black - Nero  
**3XR2.C02.06** White - Bianco

Wire - Cavo elettrificato: 300cm

**3XR2.C03.02** Black - Nero  
**3XR2.C03.06** White - Bianco

Wire - Cavo elettrificato: 500cm



**3XR2.C13.02** Black - Nero  
**3XR2.C13.06** White - Bianco

Canopy with no device on board. Black wire 300cm  
Place the device in remote position.  
*Rosone senza trasformatore. 300cm di cavo nero elettrificato. Posizionare il trasformatore in remoto.*

Accessories for Recessed, Surface and Pendant 48V track system

*Accessori comuni per binario 48V nelle versioni: incasso senza bordo, plafone e sospensione*



**1XR.TC1.02** Black - Nero  
**1XR.TC1.06** White - Bianco

End cup for track - *Tappo chiusura binario*



**1XR.TF1.02** Black - Nero  
**1XR.TF1.06** White - Bianco

End cup with hole - *Tappo con foro per chiusura binario*



**1XR.CE3.02** 300cm. Black - Nero  
**1XR.CE3.06** 300cm. White - Bianco

Aesthetic track cover - *Chiusura estetica binario*



**1XR.CUT**

Cutting tool for track conductors - *Cesoia per ridurre i conduttori*



**1XR.TE1.02** Black - Nero  
**1XR.TE1.06** White - Bianco

Short end - Feed - *Testata di alimetazione ridotta*



**1XR.GEC.02** Black - Nero  
**1XR.GEC.06** White - Bianco

Electrified jointing connector - *Giunto passante elettrificato*



**1XR.GEA.02** Black - Nero  
**1XR.GEA.06** White - Bianco

Adjustable electrified corner - *Giunto elettrificato flessibile*



**1XR.GMC.02** Black - Nero

Non electrified jointing connector - *Giunto passante non elettrificato*



## Vademecum

### MC-E

MacAdams step:

é un parametro attraverso il quale si definisce il grado di decadimento del colore della luce di una sorgente led nel tempo. Lo step 3 rappresenta ad oggi il livello di decadimento più basso.

it is a parameter which defines the deterioration degree of the colour of the light coming from a led source during its life. Step 3 is nowadays the lower deterioration level.

es ist ein Parameter, der der Verschlechterungsgrad der Lichtfarbe eines Led Leuchtmittels während seines Lebens bestimmt. Step 3 ist heutzutage das niedrigste Verschlechterungsniveau.

Est un paramètre avec le quel on défini le degré de détérioration de la couleur de la lumière d'une source led dans le temps. Aujourd'hui le Step 3 est le niveau de détérioration le plus bas.

el es un parámetro que define el grado de deterioración del color de la luz de una fuente led en el tiempo. El step 3 representa hoy el nivel de deterioración más bajo.

### CRI

Indice di resa cromatica di una sorgente luminosa, e misura di quanto naturali appaiano i colori degli oggetti da essa illuminati.

Colour Rendering Index of a light source and measure indicating how natural the colours of objects appear when enlightened from it.

Farbwiedergabeindex einer Lichtquelle und Maß, das, wie nach der Natur die Farben der Objekten sich herausstellen, wenn sie von dieser Lichtquelle beleuchtet sind, anzeigt.

Indice de rendu des couleurs d'une source lumineuse et mesure qui indique la pureté des couleurs des objets éclairés par cette source.

Indice de rendimiento lumínico de una fuente luminosa, y medida de lo natural del color de los objetos iluminados con dicha fuente.

### lm

Il lumen è l'unità di misura del flusso luminoso di una sorgente luminosa. Lumen is the unit of the light flux of a light source.

Lumen ist ein Maß der Strahlengang einer Lichtquelle.

Le lumen est l'unité de mesure du flux d'éclairage d'une source lumineuse.

El lumen es la unidad de medida del flujo luminoso de una fuente luminosa.

### lx

Il lux è l'unità di misura per l'illuminamento di un'area piana. Un lux è pari a un lumen fratto un metro quadrato.

Lux is the unit for the lighting of a flat area. One lux is equal to one lumen divided per one square meter.

Lux ist ein Maß für die Beleuchtung einer ebenen Oberfläche. Ein lux ist gleich ein lumen geteilt durch einen quadratischen Meter.

Le lux est l'unité de mesure pour l'illumination d'une zone plane. Un lux correspond à un lumen divisé par mètre carré.

El lux es la unidad de medida de iluminación de una superficie. Un lux es equivalente a un lumen por metro cuadrado.

### ⚡

Classe I: Le componenti elettriche accessibili sono collegate ad un conduttore di terra.

Class I: Only basic insulation, accessible conductors are earthed. Earthing compulsory.

Klass I: Grundisolation leitenden; berührbare Metallteile sind mit Schutzerdung verbunden. Schtzerdung vorgeschriben.

Class I: Seulement isolation de base, les parties conductrices accessibles sont reliées à un conducteur terre. Mise à la terre obligatoire.

Clase I: Sólo aislamiento fundamental; además, las partes conductoras accesibles están conectados a un conductor de tierra. Puesta a tierra indispensable.

### □

Classe II: Messa a terra esclusa, sostituita da cavi elettrici con un isolamento rinforzato.

Class II: basic insulation plus second insulation or both are replaced by reinforced insulation. Earthing excluded

Klasse II: Entweder zu der Grundisolierung kommt noch eine zweite Isolierung hinzu oder ist eine verstrebtten Isolierung vorgesehen.

Class II: Soit à l'isolation, soit ces deux dernières sont remplacées par une isolation renforcée.

Mise à la terre: excluse.

Clase II: Al aislamiento fundamental se añade un segundo aislamiento, o bien los dos aislamientos se reemplazan por un aislamiento reforzado.

### ⚡

Classe III: Alimentazione a bassa tensione, inferiore a 50V-50Hz. Messa a terra non prevista.

Class III: Low tension inferior to 50V-50Hz. No ground cable.

Klasse III: Niedervolt < 50V-50 HZ, ohne Erdung

Class III: Alimentation de sécurité à basse tension.

Ne doit en aucun cas être utilisée pour des tensions supérieures à 50V-50Hz. mise à la terre.

Clase III: Alimentación de baja tensión, inferior a 50V-50Hz. Toma de tierra no prevista.

### ⚠

Apparecchio con caratteristiche per il montaggio diretto su superfici normalmente infiammabili (EN 60 598/VDE 0711).

Device which can be mounted on flammable surfaces (EN 60 598/VDE 0711).

Aparato con características para el montaje directo sobre superficies normalmente inflamables (EN 60 598/VDE 0711).

### CE

Prodotto conforme alle direttive europee.

Products complying with the Eur. Comm. rules.

Produkt gemaess den EU-Normen.

Producido conforme a las directivas europeas.

## IP identification

### IP0X

nessuna protezione  
no protection  
kein Schutz  
Driver fourni  
sin protégé  
sin protección

### IP1X

protezione contro corpi estranei ≥ 50mm  
protection against solid objects ≥ 50mm  
Schutz gegen Fremdkörpern ≥ 50mm  
protection contre des corps étrangers ≥ 50mm  
protegido contra objetos extraños ≥ 50mm

### IP2X

protezione contro corpi estranei ≥ 12mm  
protection against solid objects ≥ 12mm  
Schutz gegen Fremdkörpern ≥ 12 mm  
protection contre des corps étrangers ≥ 12mm  
protegido contra objetos extraños ≥ 12mm

### IP3X

protezione contro corpi estranei ≥ 2,5mm  
protection against solid objects ≥ 2,5mm  
Schutz gegen Fremdkörpern ≥ 2,5mm  
protection contre des corps étrangers ≥ 2,5mm  
protegido contra objetos extraños ≥ 2,5mm

### IP4X

protezione contro corpi estranei ≥ 1mm  
protection against solid objects ≥ 1mm  
Schutz gegen Fremdkörpern ≥ 1mm  
protection contre des corps étrangers ≥ 1mm  
protegido contra objetos extraños ≥ 1mm

### IP5X

protezione da polvere  
dust-protected  
Staubgeschützt  
protection contre la poussière  
aparato protegido contra el polvo

### IP6X

stagno alla polvere  
dust-proof  
Staubdicht  
hermétique à la poussière  
aparato totalmente protegido contra el polvo

### IPX0

nessuna protezione  
no protection  
kein Schutz  
non protégé  
sin protección

### IPX1

protezione contro caduta acqua verticale  
protected against water drops falling vertically  
Schutz gegen Wassertropfen, die senkrecht herabfallen  
protégé contre les gouttes d'eau tombant verticalement  
protegido contra la caída de gotas de agua

### IPX2

protezione contro caduta di gocce oblique a 15°  
protected against water drops max inclination 15°  
Schutz gegen Wassertropfen, die senkrecht herabfallen Neigung 15°  
protégé contre les gouttes d'eau à inclinaison maximale de max 15°  
protegido contra la caída de gotas de agua con inclinación max 15°

### IPX3

protezione contro caduta di gocce oblique a 60°  
protected against water drops max inclination 60°  
Schutz gegen Wassertropfen, die senkrecht herabfallen Neigung 60°  
protégé contre les gouttes d'eau à inclinaison de max 60°  
protegido contra la caída de gotas de agua con inclinación max 60°

### IPX4

protezione contro spruzzi d'acqua  
protected against sprinkling water  
Spritzwassergeschützt  
protégé contre les éclaboussures  
aparato protegido contralasalpicaduras

### IPX5

protezione contro getti d'acqua  
protected against water jets  
Wasserstrahlgeschützt  
protégé contre les gouttes d'eau  
aparato totalmente protegido contra los chorros de agua

### IPX6

protezione contro inondazioni  
Potected against flooding  
Überschwemmunggeschützt  
rotected against flooding  
aparato totalmente protegido contra

### IPX7

protezione per immersione temporanea  
protected against brief immersions  
gegen kurzen Tauchen geschutzt  
hermétique à la immersion  
aparato totalmente protegido contra la sumersión

### IPX8

protezione per immersione costante  
protected against long immersion  
Tauchengeschützt  
protégé pour des immersions prolongées  
aparato totalmente protegido contra la larga imersión

