

hoverinfo@boverusa.com
www.boverusa.com**Slend - Set 6**

Name: Slend - Set 6

Design: Christophe Mathieu / 2014

Typology: Pendant lamp

Environment: Indoor

Technical description:

Spun aluminum pendant in 6 separate and different shapes on 1 central round canopy. Finishes are of Brilliant Black with Black canopy, Brilliant White with White canopy or Polished Aluminum with White Canopy. Copper lined aperture houses direct light source from LED lamp. Canopy features slots for the cable connection of fixtures to allow adjustability on placement of the cluster. Height adjustable cable in transparent for Polished Aluminum, white for Brilliant White fixtures or black for Brilliant Black fixtures.

Lamps description



 Grounding: compulsory

 6 x 5 W GU10 LED

Voltage: 120V~60Hz

2 Boxes:

 1 Box 21.65 x 21.65 x 9.84 inches
Vol.: 2.6698 ft³ Weight: 11.02 lbs

 1 Box 16.14 x 20.47 x 40.55 inches
Vol.: 7.7551 ft³ Weight: 39.68 lbs
Certifications:  
 Photometrics made according to the position the lights are shown in the catalogue and price list.

Ref

Finishings

2560520064U	Polished Aluminum White Canopy Transparent Wire
-------------	---

2560520001U	Brilliant White White Canopy White Wire
-------------	---

2560520023U	Brilliant Black Black Canopy Black Wire
-------------	---

LED bulb included

Adjustable height by the user

Includes two fittings of each (Slend 01, 02, 03) with the same finishings.

Special colors: RAL number to be indicated. Minimum quantity: 5 pieces.

Customizable

Measures

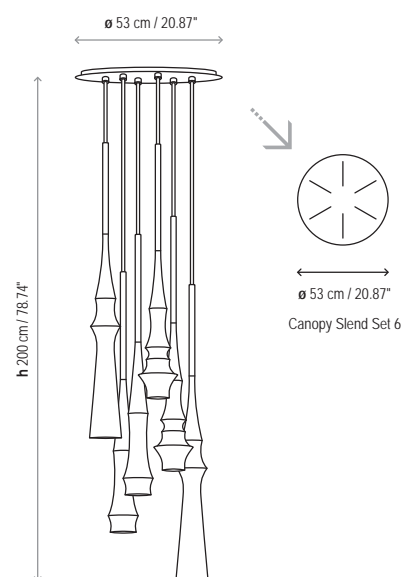

Slend - 01

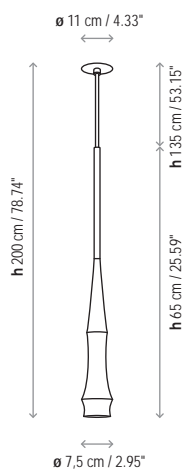

Slend - 02

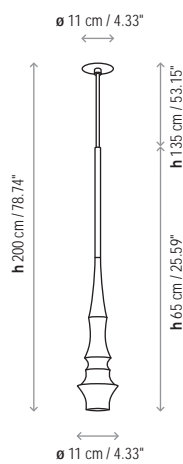

Slend - 03

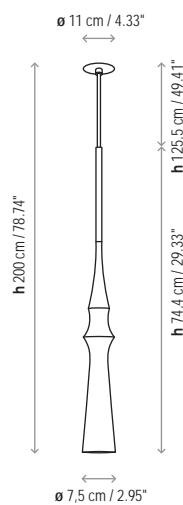

Slend - Set 3 Round

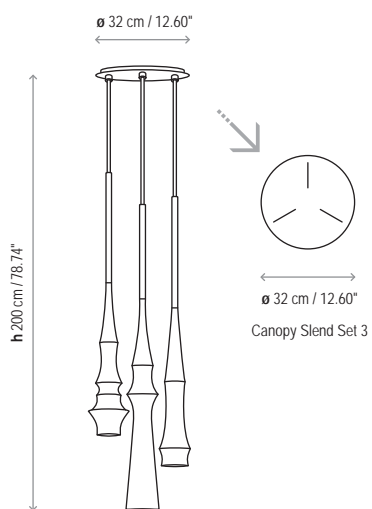

Slend - Set 3 Lineal

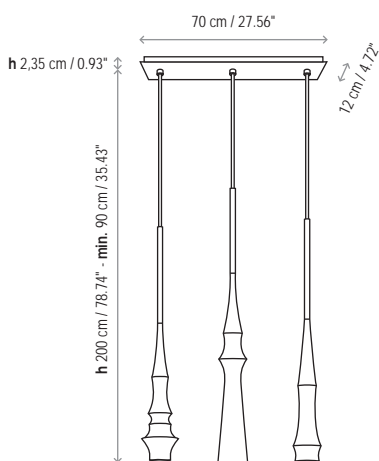

Slend - Set 6

