

technics

1 cut out

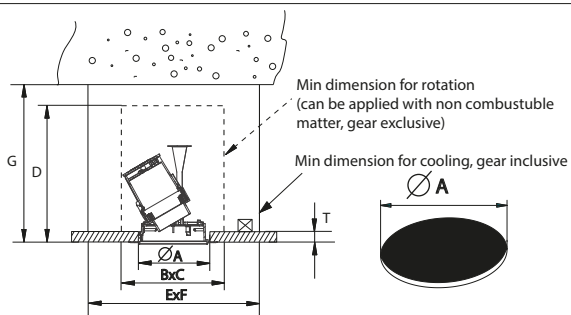

Name	Reference	Lamptype	∅A	BxC	D <sub>min</sub>	ExF	G <sub>min</sub>	T <sub>min</sub> -T <sub>max</sub>
Plasterkit aplis in-line 120 (shadow gap)	(8)	LED dir, fixed, wallwasher	144			350x350	150	
		LED dir, fixed, wallwasher	144			350x350	150	
		LED dir low	144			400x400	140	
		LED dir low	144			400x400	140	
Plasterboard thickness 120 range								

9-26

2 dimensions

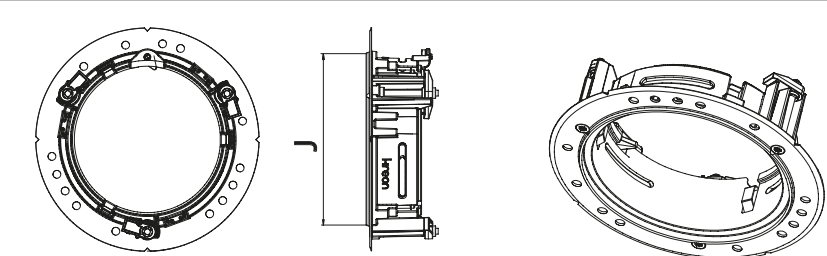

Name	Reference	Visible J
Aplis in-line 120 plasterkit no shadow gap	KR707204	∅ 120
Aplis in-line 120 plasterkit shadow gap	KR707208	∅ 126

3 installation

Round plasterkit

Put the plasterkit through the hole.

Fix the plasterkit with the screws.

Assembling torque max 20 CN.m.

4 installation

Assembling principle

Fill around perimeter of plasterkit using suitable filler and plaster to hide screws and plasterkit.

Minimum filler distance, spread out until zero.