

PROTEA CHANDELIERS | PROTEA - 700 - CEILING MOUNTED | PROTEA-700-C



DESCRIPTION

A ceiling mounted chandelier inspired by the South Africa's national flower the `Protea`. Made from lasercut stainless steel frames, chrome plated or lacquered, solid brass components and ballchain in several optional finishes. Illuminated by 13 surface mounted G9 Halogen lamps.

PRODUCT SIZE

SHADE SIZE: 700W X 700H MM / TOTAL HEIGHT: 720MM

PACKAGING DIMENSIONS

810MM(W) X 810MM(L) X 330MM(H)



LAMP TYPE & NO

13 X G9-HALOGEN 18-40 WATT LAMPS (234-520W) OR LED

CLASS I
IP RATING 20
QC RATING 21

VOLTAGE RANGE
110 - 240V

PRODUCT MARKS & RATINGS



WEIGHT 15KG
PACKED 23KG WEIGHT

TECHNICAL DRAWING

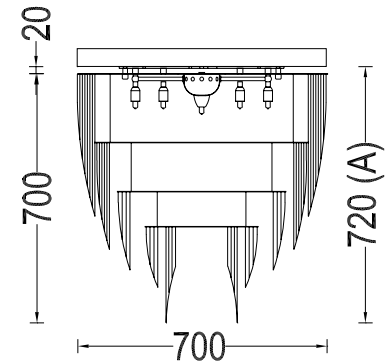
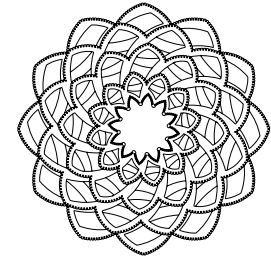

INTERACT

SELECT COLOUR

- SILVER *
- BRASS *
- COPPER *
- SMOKE *
- MIXED METALIC *
- RUST *
- WHITE
- RED
- BLACK

* METALLIC

CUSTOMISE DIMENSIONS

A

LAMP TYPE

QUANTITY

ADDITIONAL COMMENTS