

Products / Stools & Ottomans / Ufo Bar Stool

# Ufo bar stool

by Ora İto

The UFO design furniture collection, designed by Ora İto for Vondom, results from “genetic mutation experiments” between the iconic languages of pagodas and UFOs. It is characterised by the **opposition of negative and positive shapes**.

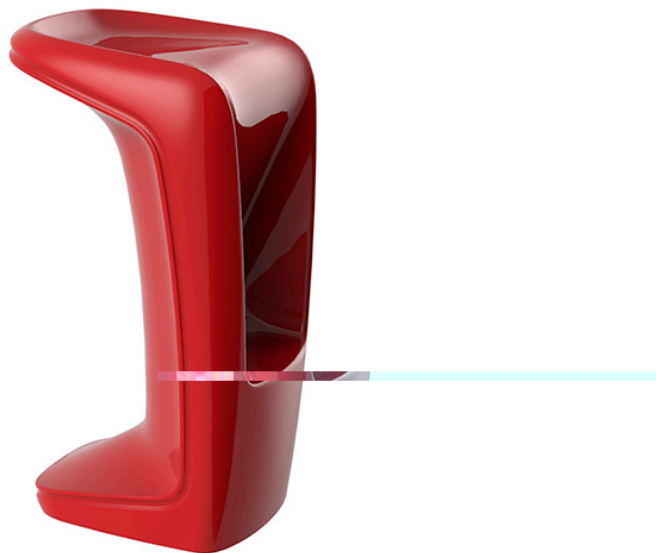

# Info

---

## Description

Made of polyethylene resin by rotational moulding. 100% Recyclable. Item suitable for indoor and outdoor use. Available in different finishes.

Weight: 6 Kg

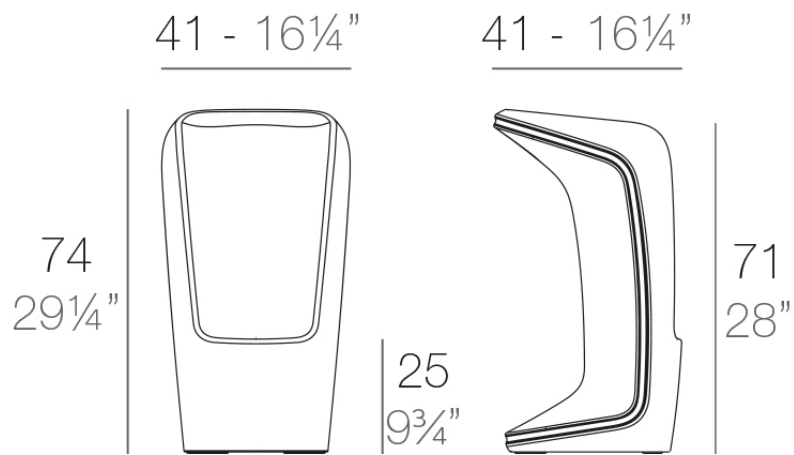

UFO Taburete Alto  
UFO Bar Stool

# Finishes

---

## finishes

---

### BASIC

Ref. 63005



purjai red



white



black



bronze



steel



anthracite



red



khaki

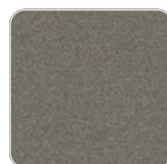

taupe



ecru



beige



orange



notte blue



crema



green

### Matt Polyethylene

### LACQUERED

Ref. 63005F



modo green



purjai red

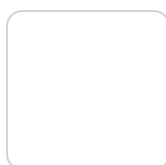

white



black



bronze



steel



anthracite



champany



red



khaki



taupe



ecru



beige

Lacquered Polyethylene

## lighting

---

### LIGHT

Ref. 63005W

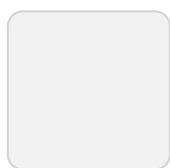

ice

White internally lit unit with LED technology. Available only in matte ice white finish.

### RGBW LED

Ref. 63005L

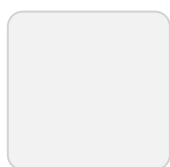

ice

Unit with internal lighting with RGBW LED technology and remote control unit for switching colors. Available only in matte ice white finish. Remote control included.  
RGBW LED BATTERY

Ref. 63005Y

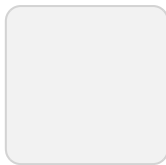

ice

Unit with internal lighting with battery-powered RGBW LED technology. Includes charger and remote control for switching colors and charger. Available only in matte ice white finish.

RGBW LED DMX BATTERY

Ref. 63005DY

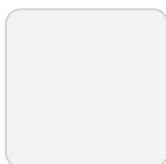

ice

Unit with internal lighting with RGBW LED technology and remote control unit for switching colors. Also controlled by DMX-1024 (wireless), enabling communication between one or more products simultaneously via the DMX transmitter (not included). There are two options to choose from: Professional XLR DMX and Home WIFI DMX. (Remote control included).

# Ambients

---

