

# Installation Guide



**Saona**  
ref. 33803



**WHERE ARE WE**

Calle Dinámica N°1, Pol. Ind. Santa Rita  
08755 Castellbisbal, Barcelona SPAIN



**CALL US**

Ph +34 918 315 425  
Fax +34 937 720 018



**DOWNLOAD**



faro@lorefar.com  
www.faro.es



**FOLLOW US**



## >> ESPAÑOL

Felicidades por la compra de su nuevo ventilador Faro Barcelona que le proporcionará, diseño, calidad y confort durante muchos años. Estamos orgullosos de nuestro trabajo y apreciamos la oportunidad de suministrarle uno de los mejores ventiladores de techo disponibles. ¡Toca empezar a disfrutar de su ventilador de techo Faro Barcelona!

## >> CATALÀ

Felicitats per la compra del seu nou ventilador Faro Barcelona que li proporcionarà, disseny, qualitat i confort durant molts anys. Estem orgullosos del nostre treball i apreciem l'oportunitat de subministrar-li un dels millors ventiladors de sostre disponibles. Comenci a gaudir del seu ventilador de sostre Faro Barcelona!

## >> ENGLISH

Congratulations on the purchase of your new Faro Barcelona fan that will provide you, design, quality and comfort for many years. We are proud of our work and appreciate the opportunity to provide one of the best ceiling fans available. It's time to start enjoying your Faro Barcelona ceiling fan!

## >> FRANÇAIS

Félicitations pour l'achat de votre nouveau ventilateur Faro Barcelona qui vous apportera design, qualité et confort pendant de nombreuses années.

Nous sommes fiers de notre travail et apprécions l'opportunité de fournir l'un des meilleurs ventilateurs de plafond disponibles. Il est temps de commencer à profiter de votre ventilateur de plafond Faro Barcelona!

## >> ITALIANO

Congratulazioni per aver acquistato un ventilatore Faro Barcelona che le garantirà design, qualità e comfort per molto tempo. Siamo orgogliosi del nostro lavoro e apprezziamo molto che ci abbia dato l'opportunità di fornirle uno dei migliori ventilatori da soffitto disponibili nel mercato. Cominci ad utilizzare il suo nuovo ventilatore da soffitto Faro Barcelona!

## >> PORTUGÊS

Parabéns pela compra do seu novo ventilador de Faro Barcelona que lhe proporcionará design, qualidade e conforto por muitos anos. Estamos orgulhosos do nosso trabalho e apreciamos a oportunidade de fornecer um dos melhores ventiladores de teto disponíveis. É hora de começar a desfrutar do seu ventilador de teto Faro Barcelona!

## >> DEUSTCH

Herzlichen Glückwunsch zum Kauf Ihres neuen Faro Barcelona Ventilators, der Ihnen Design, Qualität und Komfort für viele Jahre bieten wird. Wir sind stolz auf unsere Arbeit und schätzen die Möglichkeit, Ihnen einen der besten Deckenventilatoren zu

liefern.

Es ist an der Zeit, Ihren Faro Barcelona Deckenventilator zu genießen!

## >> NEDERLANDS

Gefeliciteerd met de aankoop van uw nieuwe Faro Barcelona ventilator. Deze zal u kwaliteit en confort bieden voor vele jaren. Wij zijn trots op ons werk, en waardeeren de mogelijkheid om u een van de beste beschikbare plafondventilatoren te leveren. Geniet van uw nieuwe Faro Barcelona plafondventilator!

>> ΕΛΛΗΝΙΚΗ Συγχαρητήρια για την αγορά του νέου σας ανεμιστήρα Faro Barcelona που θα σας προσφέρει ντιζάιν, ποιότητα και άνεση για πολλά χρόνια.

Είμαστε υπερήφανοι για την δουλειά μας και εκτιμούμε την ευκαιρία να σας προσφέρουμε έναν από τους καλύτερους ανεμιστήρες οροφής της αγοράς. Ήρθε η ώρα να απολαύσετε τον ανεμιστήρα οροφής Faro Barcelona!

## >> РУССКИЙ

Поздравляем вас с приобретением вентилятора Faro Barcelona нового поколения, который будет радовать вас своим дизайном, качеством и комфортом в течение многих лет. Мы гордимся нашей работой и ценим возможность предоставить вам один из лучших потолочных вентиляторов. Пришло время начать

наслаждаться потолочным вентилятором Faro Barcelona!

>> ĀESKY Gratulujeme vám k zakoupení vašeho nového ventilátoru Faro Barcelona, který vám poskytne design, kvalitu a komfort po mnoho let.

Jsme hrdí na naši práci a vážíme si příležitosti poskytnout vám jeden z nejlepších stropních ventilátorů na trhu. Je načase začít si užívat váš stropní ventilátor Faro Barcelona!

>> POLSKI Gratulujemy zakupu nowego wentylatora Faro Barcelona, który zapewni Ci design, jakość i komfort przez wiele lat. Jesteśmy dumni z naszej pracy i doceniamy możliwość zaoferowania jednego z najlepszych dostępnych wentylatorów sufitowych. Czas zacząć cieszyć się swoim wentylatorem Faro Barcelona!

>> БЪЛГАРСКИ Поздравления за закупуването на новия вентилатор от Faro Barcelona, който ще ви осигури дизайн, качество и удобство в продължение на много години. Гордеем се с нашата продукция и оценяваме възможността да ви предоставим един от най-добрите таванни вентилатори. Време е да започнете да се наслаждавате на таванния вентилатор на Faro Barcelona!

>> **SLOVENČINA** Blahozeláme k nákupu vášho nového ventilátora Faro Barcelona, ktorý vám poskytne dizajn, kvalitu a komfort po mnoho rokov.

Sme hrdí na našu prácu a oceňujeme príležitosť poskytnúť jeden z najlepších stropných ventilátorov. Je čas začať si užívať váš stropný ventilátor Faro Barcelona!



#### >> **ESPAÑOL**

El manual de contiene las instrucciones completas para instalar y operar con su ventilador de forma segura. Recuerde apretar firmemente todos los tornillos y hacer todas las conexiones correctamente.

#### >> **CATALÀ**

Els manuals contenen les instruccions completes per instal·lar i operar amb el seu ventilador de forma segura. Recordei estrènyer fermament tots els cargols i fer totes les connexions correctament.

#### >> **ENGLISH**

The manuals contain the complete instructions for installing and operating with your fan safely. Remember to tighten all screws firmly and make all connections correctly

#### >> **FRANÇAIS**

Le manuel d'utilisation contient les instructions complètes pour installer et utiliser votre ventilateur en toute sécurité. N'oubliez pas de serrer toutes les vis fermement et de faire toutes les connexions correctement

#### >> **ITALIANO**

Il manuale operativo contiene le istruzioni complete per installare ed utilizzare il suo ventilatore in totale sicurezza. Ricordi di avvitare bene tutti i bulloni e realizzare tutte le connessioni nella maniera corretta.

#### >> **PORTUGUÊS**

O manual de operação contém as instruções completas para instalação e operação com o seu ventilador com segurança. Lembre-se de apertar firmemente todos os parafusos e fazer todas as conexões corretamente.

#### >> **DEUTSCH**

Die Betriebsanleitung enthält vollständige Anweisungen für die sichere Installation und den sicheren Betrieb Ihres Ventilators. Denken Sie daran, alle Schrauben fest anzuziehen und alle Verbindungen korrekt herzustellen.

#### >> **NEDERLANDS**

De gebruikshandleiding bevat de volledige instructies voor de installatie en de veilige bediening van uw ventilator. Vergeet niet om alle schroeven stevig vast te draaien, en alle verbinding correct aan te sluiten.

#### >> **ΕΛΛΗΝΙΚΗ**

Το εγχειρίδιο λειτουργίας περιέχει τις πλήρεις οδηγίες για την εγκατάσταση και λειτουργία με τον ανεμιστήρα σας με ασφάλεια. Θυμηθείτε να σφίξετε καλά όλες τις βίδες και να κάνετε σωστά όλη τη συνδεσμολογία.

#### >> **РУССКИЙ**

Руководство по эксплуатации содержит полные инструкции по установке и безопасному использованию вашего вентилятора. Не забудьте крепко затянуть все винты и правильно установить все соединения.

#### >> **ČESKY**

Provozní příručka obsahuje kompletní pokyny pro instalaci a bezpečný provoz vašeho ventilátoru. Nezapomeňte pevně dotáhnout všechny šrouby a vše správně připojit!

#### >> **POLSKI**

Instrukcja obsługi zawiera kompletnie wskazówki dotyczące bezpiecznego instalowania i obsługi wentylatora. Pamiętaj, aby mocno dokręcić wszystkie śruby i prawidłowo wykonać wszystkie połączenia!

#### >> **БЪЛГАРСКИ**

Ръководството за експлоатация съдържа пълните инструкции за безопасно монтиране и работа с вашия вентилатор. Не забравяйте да затегнете здраво всички винтове и да свържете правилно всички връзки.

#### >> **SLOVENČINA**

Návod na obsluhu obsahuje úplné pokyny na inštaláciu a bezpečnú prevádzku s ventilátorom. Nezabudnite pevne utiahnuť všetky skrutky a urobiť všetky pripojenia správne.

<< العربية

يحتوي الدليل على التعليمات الكاملة لتثبيت مروحة وتشغيلها بأمان. تذكر أن تشد بقوة جميع البراغي والقيام بجميع التوصيلات بشكل صحيح.

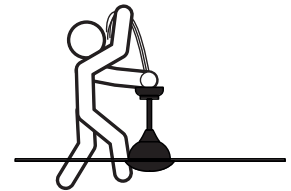
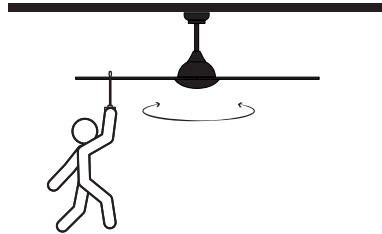
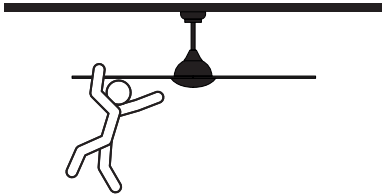
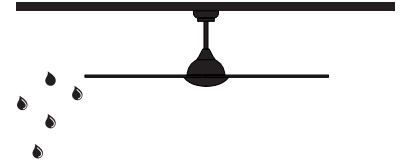
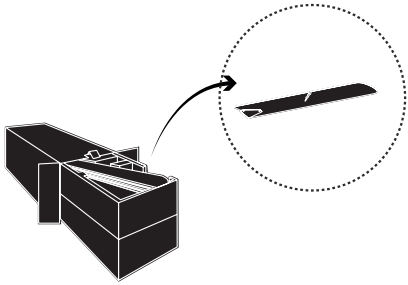

## Technical Specifications

Speeds	A	W	RPM	CFM	M <sup>3</sup> MIN	CFM/W
I - Low	0,05	5	85	2650	75	530
II	0,08	8	105	3530	100	441
III	0,11	14	126	4450	126	317
IV	0,16	21	155	5370	152	255
V - High	0,28	38	180	6643	188	175

Weight		Power	
kg	9.2	V	220-240
lb	20.2	Hz	50/60

sizes mm / inch

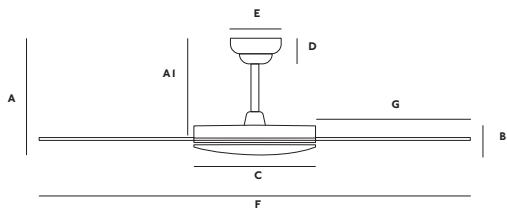

A	AI	B	C	D	E	F	G
330 / 12.99"	250 / 9.84"	150 / 5.90"	330 / 12.99"	58 / 2.29"	150 / 5.90"	1320 / 51.97"	490 / 19.29"

 SMD LED 24W 3000K 990lm <input checked="" type="checkbox"/>	
---	---

			 RF <input checked="" type="checkbox"/>	 DC		 max 15°
						



**Saona**  
ref. 33803

### Motor

Material	Steel
Finished	White

### Blades

Material	ABS
Finished	White

### Light Kit

Material	Glass
Finished	Opal White



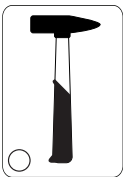
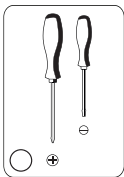
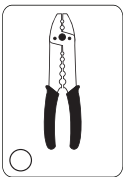
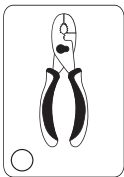

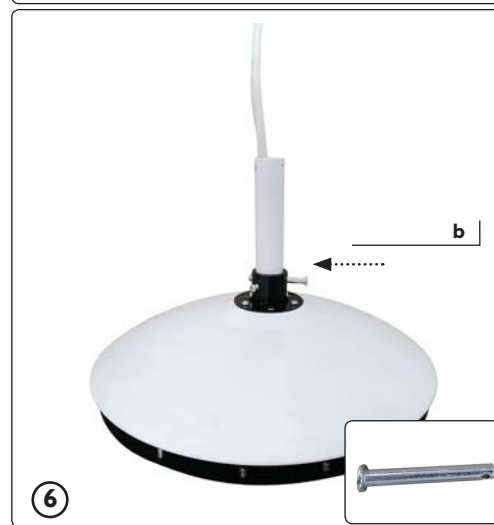
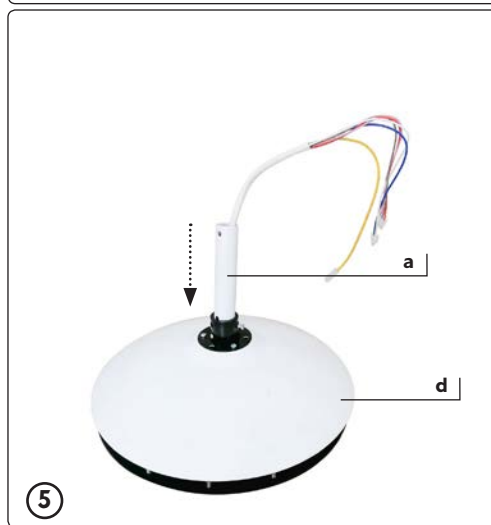
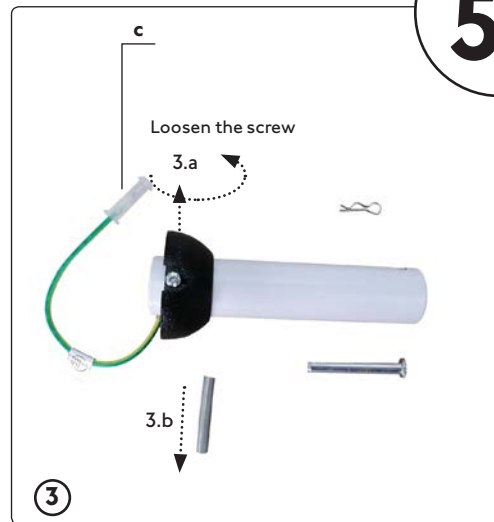
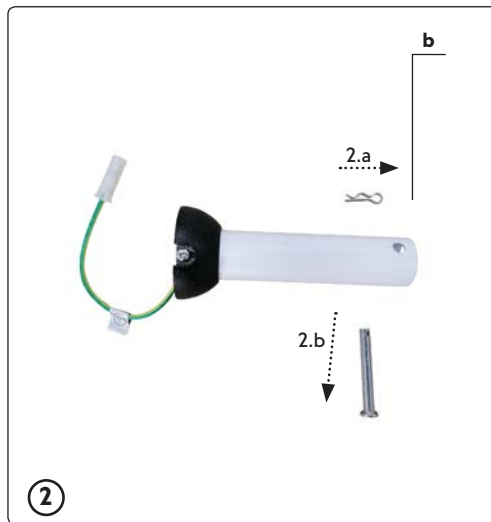
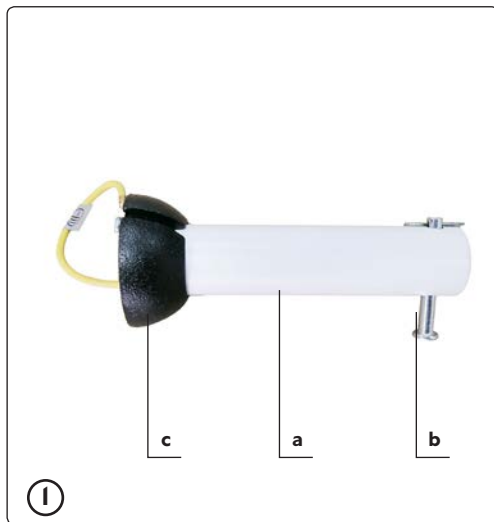

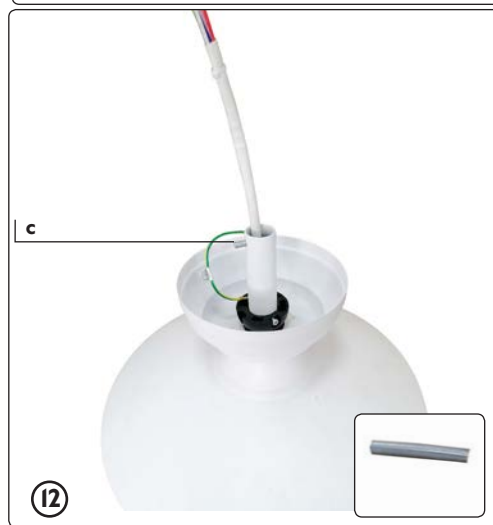
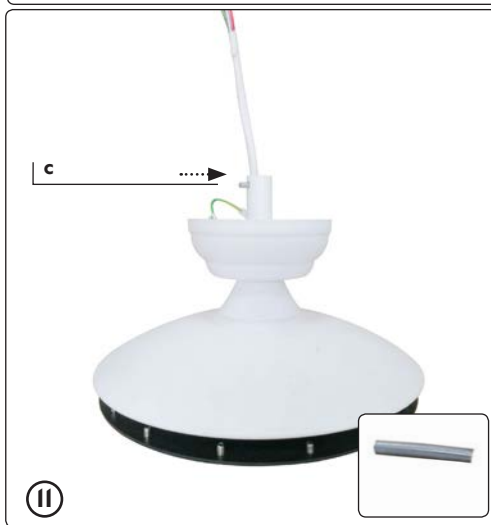
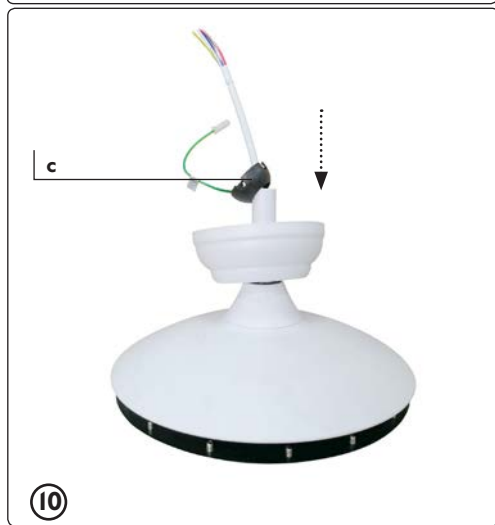
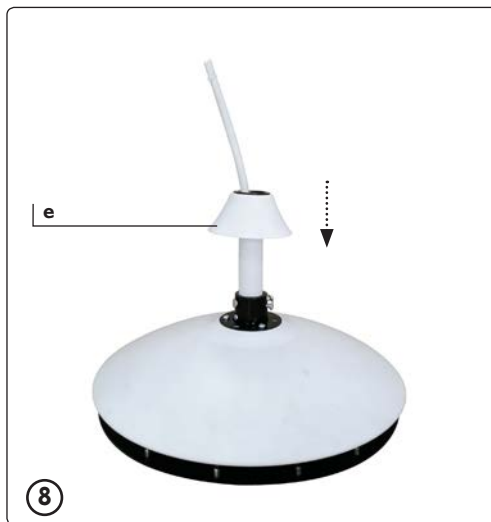
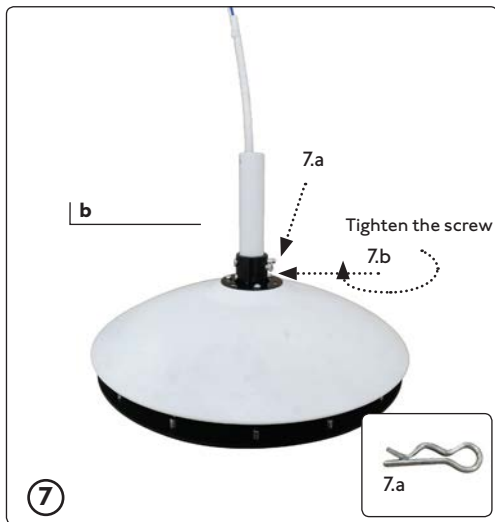



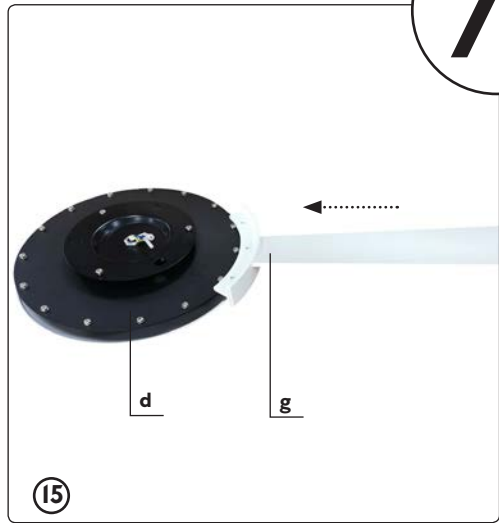
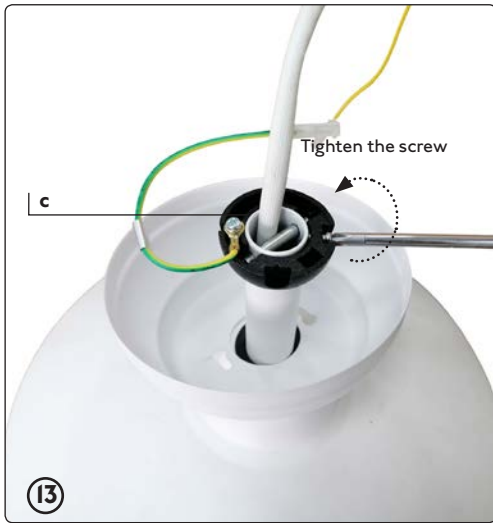

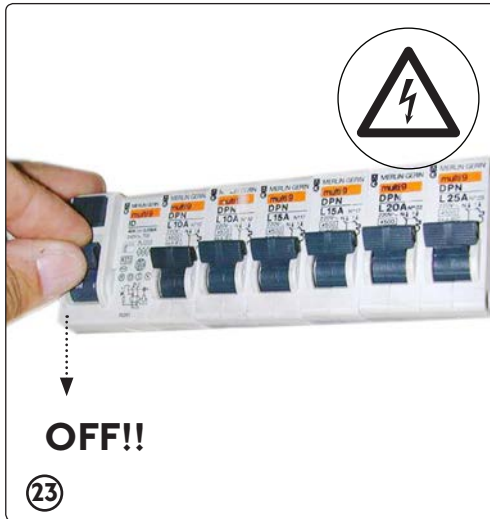
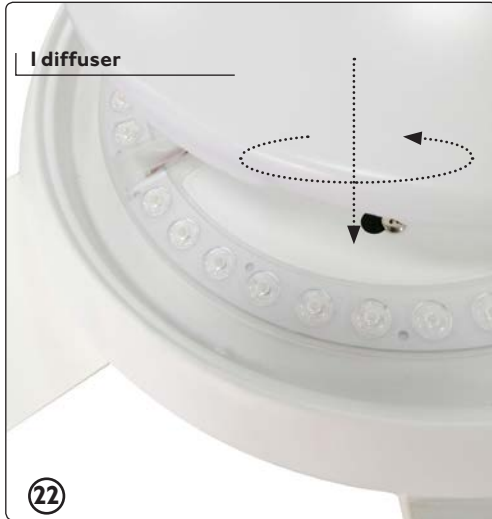

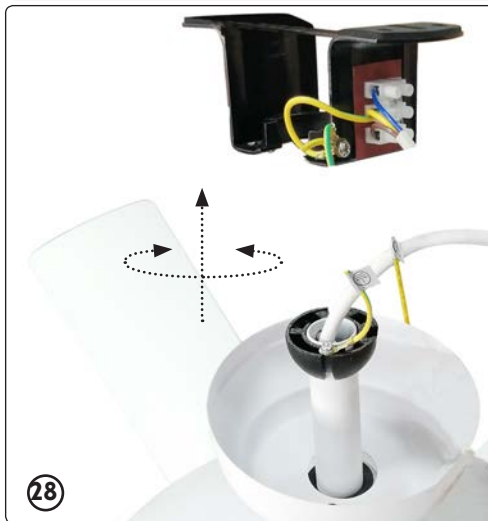
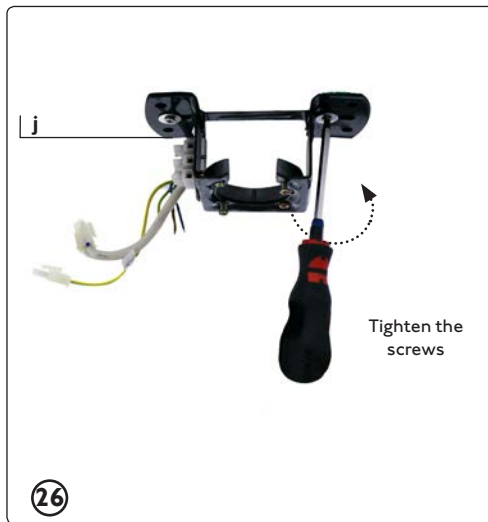
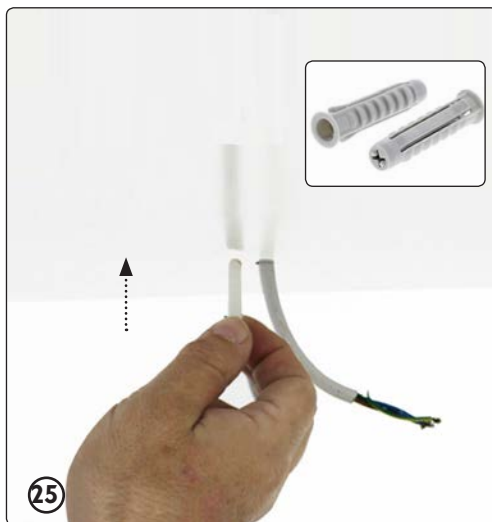

i faqs - [www.faro.es](http://www.faro.es)

HOUSEHOLD  
220V-240V  
L N ⊕

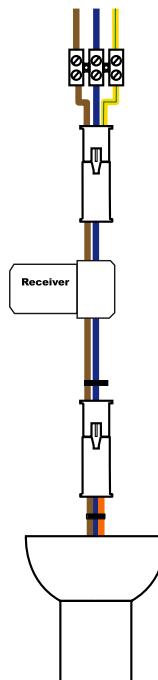

L - marrón, marró,  
brown, marron, marrone,  
castanho, braun, bruin,  
καφέ, коричневый, hnědá,  
brażowy, кафяв, hnědý  
بني

N - azul, blau, blue, bleu,  
blu, azul, blau, blauw,  
μπλε, синий, modrá, nie-  
bieski, син, modrý  
أزرق

⊕ - amarillo-verde,  
groc-verd, yellow-green,  
jaune-vert, giallo-verde,  
verde-amarelo, gelb-grün,  
gell-groen, κίτρινο-  
πράσινο, желто-зеленый,  
žlutozelená, żółto-zielony,  
жълто-зелен, žltozelená  
أصفر - أخضر

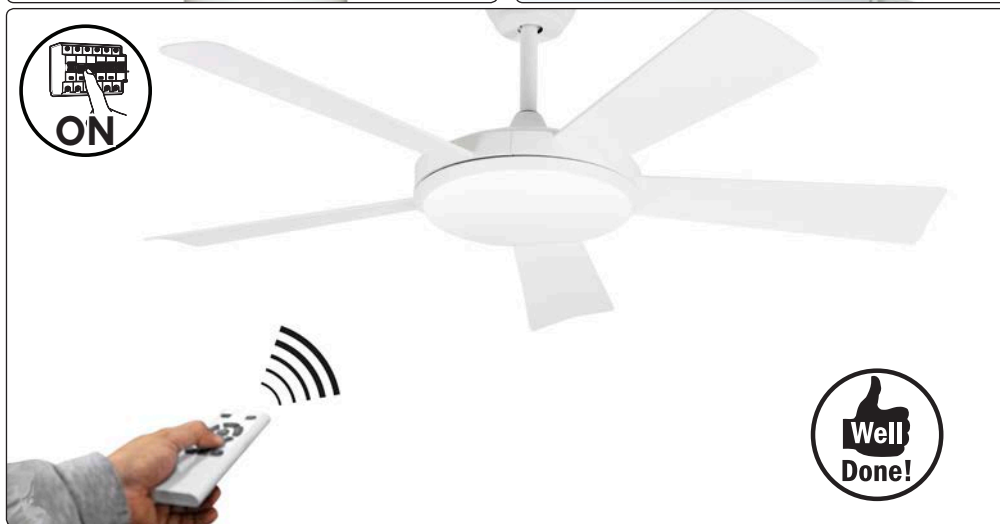
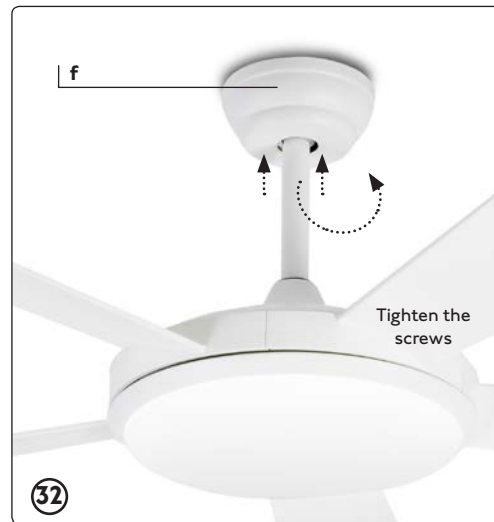
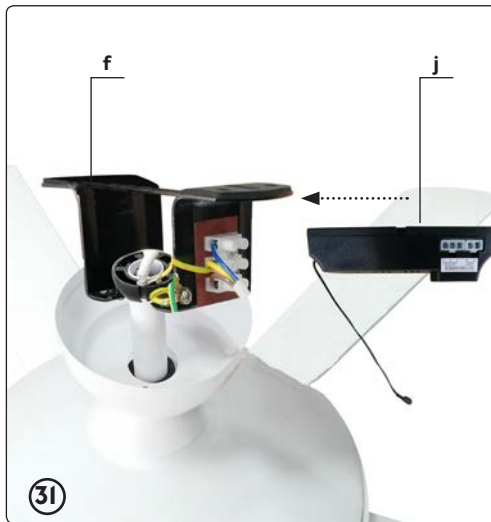
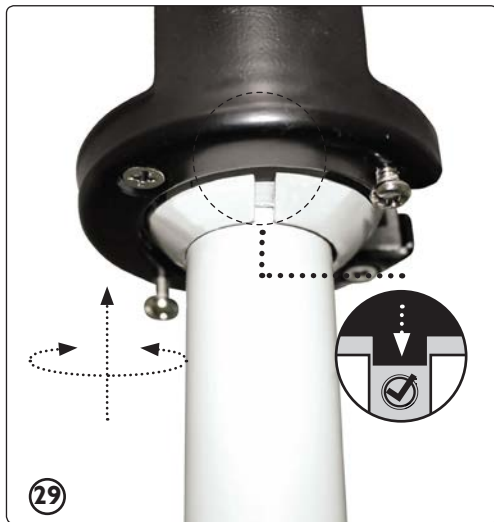

# Remote control

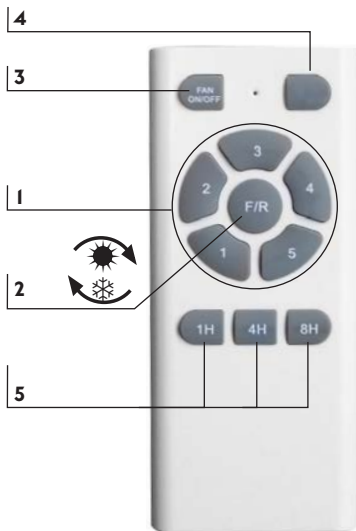

## ESPAÑOL TRANSMISOR

- 1- Velocidad
- 2- Función inversa
- 3- Encendido y apagado del ventilador
- 4- Luz
- 5- Programable: Funcionará 1h, 4h o 8h

## CATALÀ COMANDAMENT

- 1- Velocitat
- 2- Funció inversa
- 3- Encen i apaga el ventilador
- 4- Llum
- 5- Programable: Funcionará h, 4h o 8h

## ENGLISH TRANSMITTER

- 1- Fan speed
- 2- Reverse function
- 3- On off for fan
- 4- Light
- 5- With Programmer: It will works for 1h, 4h, 8h

## FRANÇAIS L'EMETTEUR

- 1- Vitesses
- 2- Interrupteur a sens inverse pour changer la direction du tour du ventilateur
- 3- On/off ventilateur
- 4- Lumiere
- 5- Avec Programmeur: Fonctionne pendant 1h, 4h, 8h

## ITALIANO TELECOMANDO:

- 1- Velocità
- 2- Senso di rotazione del ventilatore, in avanti o indietro.
- 3- On/off ventola
- 4- Luce
- 5- Programmabile. Finziona per 1t, 4t, 8t

## PORTUGÊS TRANSMISSOR

- 1- Velocidades da ventoinha
- 2- Controla a direcção de rotação, para a frente ou para trás
- 3- Começando marcha e desemprego do ventonhã
- 4- Luz
- 5- Programável: Funciona por 1h, 4h, 8h

## NEDERLANDS BEDIENINGSKNOPPEN OP DE ZENDER

- 1- Snelheid van de ventilator
- 2- Inverse functie
- 3- Onn/off Verlichting
- 4- Verlichtingsset
- 5- Programmeerbare: Werkt voor 1t, 4t, 8t

## DEUTSCH TASTEN AM SENDER

- 1- Ventilatorgeschwindigkeit
- 2- Umkehrfunktion
- 3- On/off ventilator
- 4- Verlichtingsset
- 5- Programmierbar: Arbeitet für 1s, 4s, 8s

## ΕΛΛΗΝΙΚΗ ΤΗΛΕΧΕΙΡΙΣΤΗΡΙΟΥ

- 1- Ταχύτητα
- 2- Αντίστροφη συνάρτηση
- 3- Εντός και εκτός του ανεμιστήρα
- 4- Φωτισμού
- 5- Προγραμματιζόμενη: Λειτουργεί για 1, 4, 8 ώρες

## РУССКИЙ ПЕРЕДАЮЩЕГО УСТРОЙСТВА

- 1- Скорость
- 2- Положение переключателя скоростей на период жаркой или холодной погоды
- 3- Позиция выключения вентилятора
- 4- Освещения press
- 5- Программируемые: Работает 1, 4, 8 часов

## ČESKY OVLÁDACÍ TLAČÍTKA VYSÍLAČE

- 1- Otáčky ventilátoru
- 2- Inverzní funkce
- 3- On/off ventilátoru
- 4- Osvětlení
- 5- Programmable: Pracuje na 1, 4, 8 hodin

## POLSKI NADAJNIKU

- 1- Prędkości
- 2- Punkcja odwrotna
- 3- On/off wentylatora
- 4- Oświetlenia
- 5- Programowanie: Działa przez 1, 4, 8 godzin

## БЪЛГАРСКИ БУТОНИ ЗА УПРАВЛЕНИЕ НА ПРЕДАВАТЕЛЯ:

- 1- Скорост
- 2- Обратна функция
- 3- On/off вентилатора
- 4- Осветление
- 5- Програмираем: Работи за 1, 4, 8 часа

## SLOVENČINA TLAČIDLÁ NA VYSIELAČI

- 1- Rýchlost
- 2- Inverznej funkcie
- 3- On/off ventilátora
- 4- Svitidla
- 5- Programovateľný: Pracuje na 1, 4, 8 hodiny

<< العربية

سرعات المروحة

وظيفة عكسية

إطفاء المروحة. لتشغيل المروحة

الضوء

قابل للبرمجة: 1، 4، 8 ساعات



## Pre-synchronized remote control

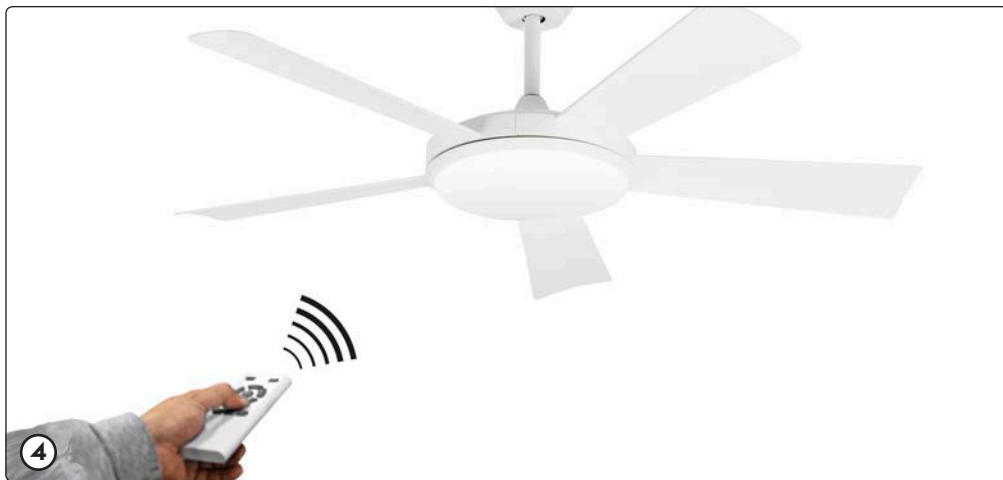



## Remote doesn't work

