

# Heathfield&Co

## Product Specification Sheet

CEILING LIGHT | RAE PENDANT



### PRODUCT INFORMATION

Base Code: PD-RAE0-SBRS-ALAB

Material: Alabaster

Finish shown: White

Flex: UK & EU 1.5 metres of Oatmeal braided flex /  
US Oatmeal braided cable

### TECHNICAL INFORMATION

Weight: 3.2kg / 7lbs

Switching & Plug: Hardwired

Lamping: 1x E27 lampholder / 1x E26 US lampholder

60W max. LED lamps recommended.

Lamps not included

TOTAL HEIGHT: 1880 mm / 74"

TOTAL WIDTH: 180 mm / 7"

UKCA / CE / UL COMPLIANT

### WARRANTY

10 years\*

### FINISHING NOTE

Alabaster is a natural material with distinctly unique formations, markings and colouration. It is part of its charm that no two lamps are exactly the same.

### CLEANING INSTRUCTIONS

The finishes on this luminaire only require regular cleaning with a soft dry duster. Abrasive or chemical cleaners may harm the finish and should not be used.

### FIXING NOTE

It is the buyer's responsibility to ensure that suitable fixings are used.

\*Please refer to our Terms & Conditions for further information.

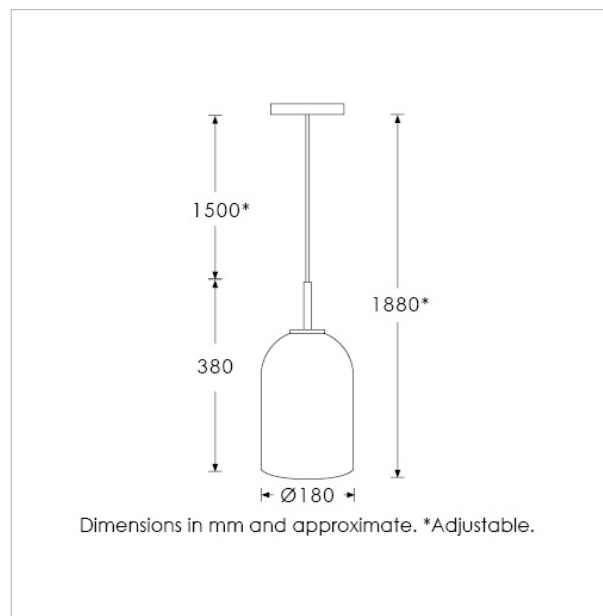

Dimensions in mm and approximate. \*Adjustable.

H&  
CO

LIGHT BEYOND DESIGN