







SUPERMORGANA design by Stefano Papi

Compendium page **304**

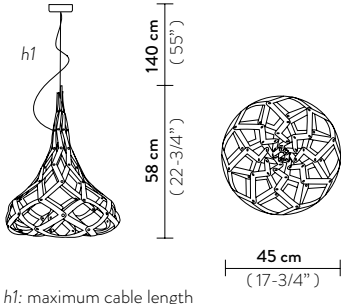
PRODUCT	SIZE	COLOUR	CODE
<p>SUSPENSION</p> <p>Bulbs G9:  1 X 2W LED</p> <p>Made of: Metallized Polycarbonate</p> <p>Weight: net Kg 0,70 - gross Kg 2,25</p> <p>Package: 50 x 50 x h65cm</p> <p>CE IP 20  </p>	 <p><i>h1</i>: maximum cable length</p>	<ul style="list-style-type: none">  MIRROR/BL  MIRROR/W.  GOLD/BLACK  GOLD/WHITE 	<ul style="list-style-type: none"> MIRROR/BL SM076S0S0000BS000 MIRROR/W. SM076S0S0000WS000 GOLD/BLACK SM076S0S0000BG000 GOLD/WHITE SM076S0S0000WG000

SUPERMORGANA ENTIRE COLLECTION

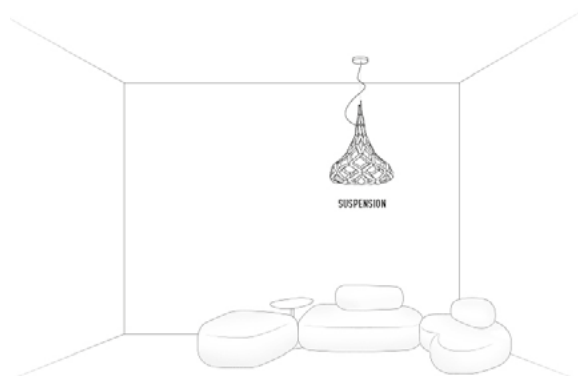

ENERGY CLASS

 This luminaire is compatible with bulbs of the energy classes: **A++**, **A+**, **A**

The luminaire is sold with a bulb of the energy class: **C**

SLAMP: SUPER MORGANA

874/2012