

SCALLOP CROPPED | SCALLOP CROPPED 150 TABLE LAMP | SCA-CRO-150(SML)-TBL



DESCRIPTION

A 150mm Dia. simple classic 'scalloped-cropped' table lamp. Made from lasercut stainless steel frames, chrome plated or lacqured, solid brass components and ballchain in several optional finishes. Illuminated by a pyrex glass ball containing a G9-Halogen or LED lamp.

PRODUCT SIZE

SHADE SIZE: 150W X 350-520H MM / TOTAL HEIGHT: 620MM

PACKAGING DIMENSIONS

300MM(W) X 300MM(L) X 800MM(H)



LAMP TYPE & NO

1 X G9-HALOGEN 33-60 WATT LAMPS (33-60W) OR LED

CLASS II
IP RATING 20
QC RATING 21

VOLTAGE RANGE
113 - 240V

PRODUCT MARKS & RATINGS



WEIGHT 3KG
PACKED 7KG WEIGHT

TECHNICAL DRAWING

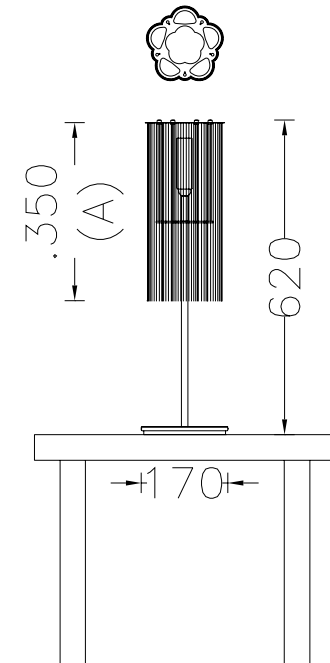

INTERACT

SELECT COLOUR

- SILVER *
- BRASS *
- COPPER *
- SMOKE *
- MIXED METALIC *
- RUST *
- WHITE
- RED
- BLACK

* METALLIC

CUSTOMISE DIMENSIONS

A

LAMP TYPE

QUANTITY

ADDITIONAL COMMENTS