

Last update on 2018-03-11 20:45. More details available at <https://www.aqform.com/en/16243>

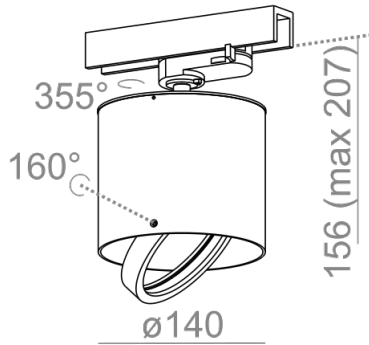

Tolerance for dimensions ± 1 mm

Warranty period 2 years

AVAILABLE FINISHES:

GLOSS STRUCTURE ADDITIONAL

TUBA 111 230V track

TUBA 111 230V track

Category: track lighting

Power 50W (LED)

Light source: ES111, 230V

Lampholder: GU10

Dimming: Phase-Control

Light source not included

Transformer not required.



TUBA 111 230V Phase-Control track

16243-0000-U8-PH-xx

-xx finish option code from table below

AVAILABLE FINISHES:

STRUCTURE

black structure	-12	white structure	-13
-----------------	-----	-----------------	-----

gold structure	-19		
----------------	-----	--	--

ADDITIONAL

grey	-16	copper	-17
------	-----	--------	-----

GLOSS

black gloss	-22	white gloss	-23
-------------	-----	-------------	-----