

SCALLOP CROPPED | SCALLOP CROPPED 280 PENDANT LAMP | SCA-CRO-280(MED)-PEN



DESCRIPTION

A 280mm Dia. simple classic `scallop-cropped` pendant lamp. Made from lasercut stainless steel frames, chrome plated or lacquered, solid brass components and ballchain in several optional finishes. Illuminated by a pyrex glass ball containing a G9-Halogen or LED lamp.

PRODUCT SIZE

SHADE SIZE: 280W X 500-700H MM / TOTAL HEIGHT: 1000MM

PACKAGING DIMENSIONS

460MM(W) X 460MM(L) X 330MM(H)



LAMP TYPE & NO

1 X G9-HALOGEN 33-60 WATT LAMPS (33-60W) OR LED

CLASS II
IP RATING 20
QC RATING 21

VOLTAGE RANGE
113 - 240V

PRODUCT MARKS & RATINGS



WEIGHT 3KG
PACKED 6KG WEIGHT

TECHNICAL DRAWING

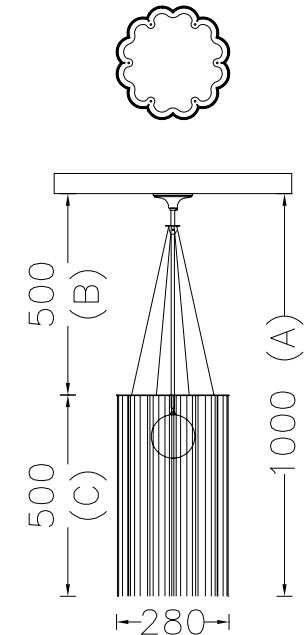

INTERACT

SELECT COLOUR

- SILVER *
- BRASS *
- COPPER *
- SMOKE *
- MIXED METALLIC *
- RUST *
- WHITE
- RED
- BLACK

* METALLIC

CUSTOMISE DIMENSIONS

A

B

C

LAMP TYPE

QUANTITY

ADDITIONAL COMMENTS